

PART NO.	STOCK CODE	VARIANTS
BE-200C	A1824	BLACK & WHITE (PAU)
BE-201C	F2088	BLACK & WHITE (NTSC)
BE-400C	A1823A	COLOUR (PAU)
BE-800C(40)	A1559	COLOUR (PAU) 40°
BE-800C(78)	A1428	COLOUR (PAU) 78°
BE-301C	A1905	COLOUR (NTSC)
BE-801C(78)	A2094	COLOUR (NTSC) 78°
BE-809C	A2371	COLOUR (PAU) NO AUDIO

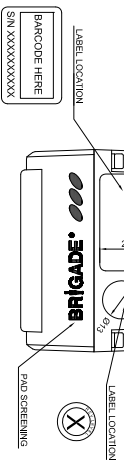
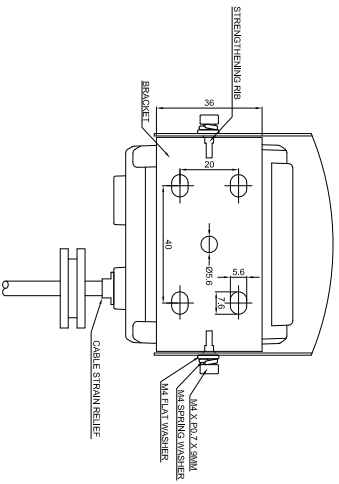
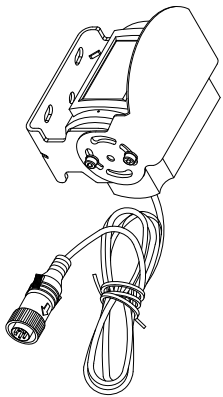
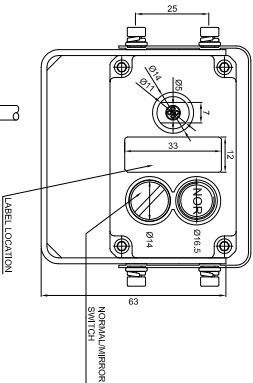
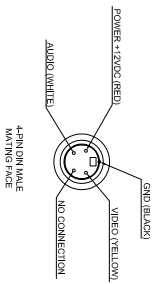
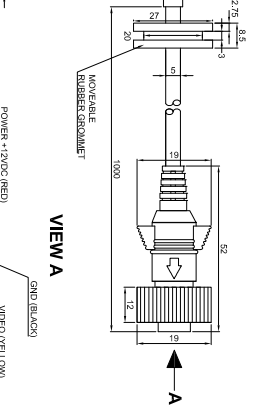
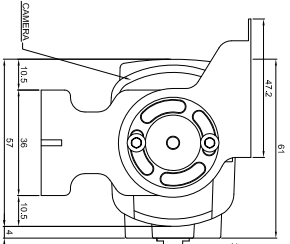
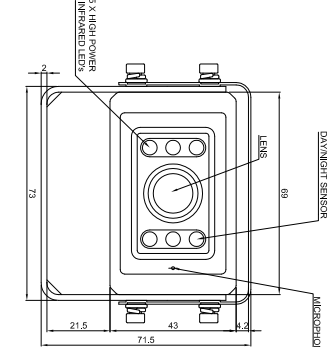
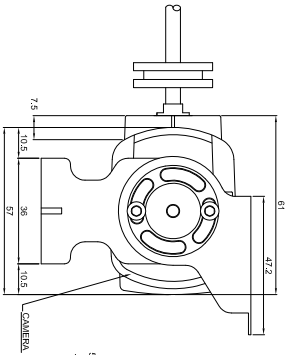
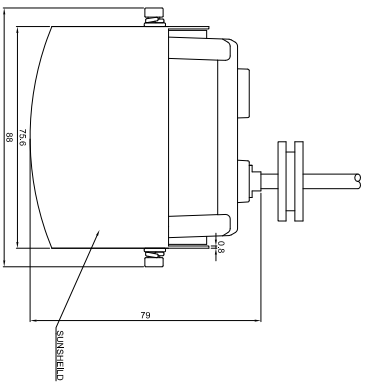

**NOTES:**  
DIMENSIONS IN MM  
REFER TO "PRODUCT SPECIFICATION" FOR MORE DETAILS

PROPRIETARY NOTE  
THIS DESIGN AND TECHNICAL INFORMATION APPEARING ON THIS DRAWING IS THE PROPERTY OF BRIGADE ELECTRONICS PLC AND IS DISCLOSED IN CONFIDENCE. IT IS NOT TO BE COPIED, REPRODUCED, REVEALED TO OR APPROPRIATE BY OTHERS, EITHER IN WHOLE OR IN PART WITHOUT THE EXPRESS WRITTEN CONSENT OF BRIGADE ELECTRONICS PLC.

Rev/No Revision note

Date

Signature/Checked

Item#	Quantity	Title/Name, designation, material, dimension etc	Article No./Reference
Designed by		Approved by - date	Filename
MBUTLER		DKERAI	CM
		SMATTREWS	17/02/09

BRIGADE ELECTRONICS

BE-801C (A1905)

BE-000697-00-09

Edition 1/1  
Sheet 1/1